



A method for multiparametric separation free bioaffinity assays for microvolumes

Juhani T Soini, Jori M Soukka, Niko J Meltola, Alekski E Soini, Juha T Haavisto, Jarkko T Kajonen, Tiina K Ojala, Kenneth Rundt, Matti E Waris, Erkki Soini and Pekka E Hänninen

Laboratory of Biophysics, Institute of Biomedicine, University of Turku, Finland

Abstract

We present a concept for multiparameter separation free micro volume bioaffinity assay. The concept is based on the use of two-photon excited fluorescence and several categories of polystyrene microspheres as a solid phase for bioaffinity binding reaction.

Measurements are performed by observing individual microspheres in the diffraction limited focal volume of two-photon excitation. The method is suitable for measuring bioaffinity binding assays directly from the reaction volume without separation and washing steps.

Instrument and immunoassay

The optical schematic of the instrument, TopDoc, is shown in **Fig 1**. The beam of the passively q-switched microchip Nd:YAG-laser at 1064 nm is focused tightly into a *cuvette*. The generated fluorescence in range 540-800 nm is measured with three fluorescence channels in coincidence with back scattering signal of the microparticles in the confocal *particle detector*. As the scattering signal appears, the *scanner* unit is stopped, and the particles are actively trapped into the focus of laser beam.

CRP assay is utilising 3.1 μm carboxy-modified polystyrene microspheres as solid phase carriers. Monoclonal mouse anti-CRP IgG molecules are covalently coupled to the microspheres. As a tracer the same IgG molecules were labelled with dipyrrometheneboron difluoride dye having single photon emission maximum at 580 nm. Analyte and reagent were mixed simultaneously and incubated in prior to measurement in the same reaction *cuvette*. The standard curve of the CRP-assay is shown in **Fig 2**. Each point of the curve comprises of an average of around 100 microparticles. The CV at the blank level was as good as 3 %.

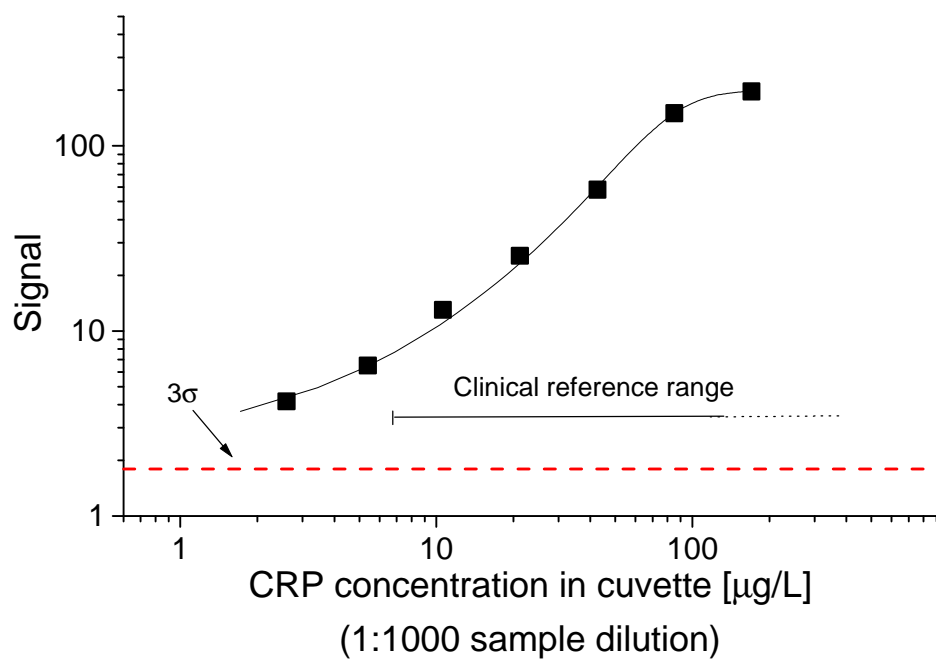

Fig 2. Standard curve of CRP-assay

To simulate a measurement of a multiparameter assay we have chosen to mix preincubated microparticles from two different immunoassays. The microspheres of assay category 2 has been doped with an identification fluorochrome having emission maximum at 650 nm. Measurement result, which is shown in **Fig 3**, as a dot plot, demonstrates the capability of the system to measure signals from two different particle categories simultaneously.

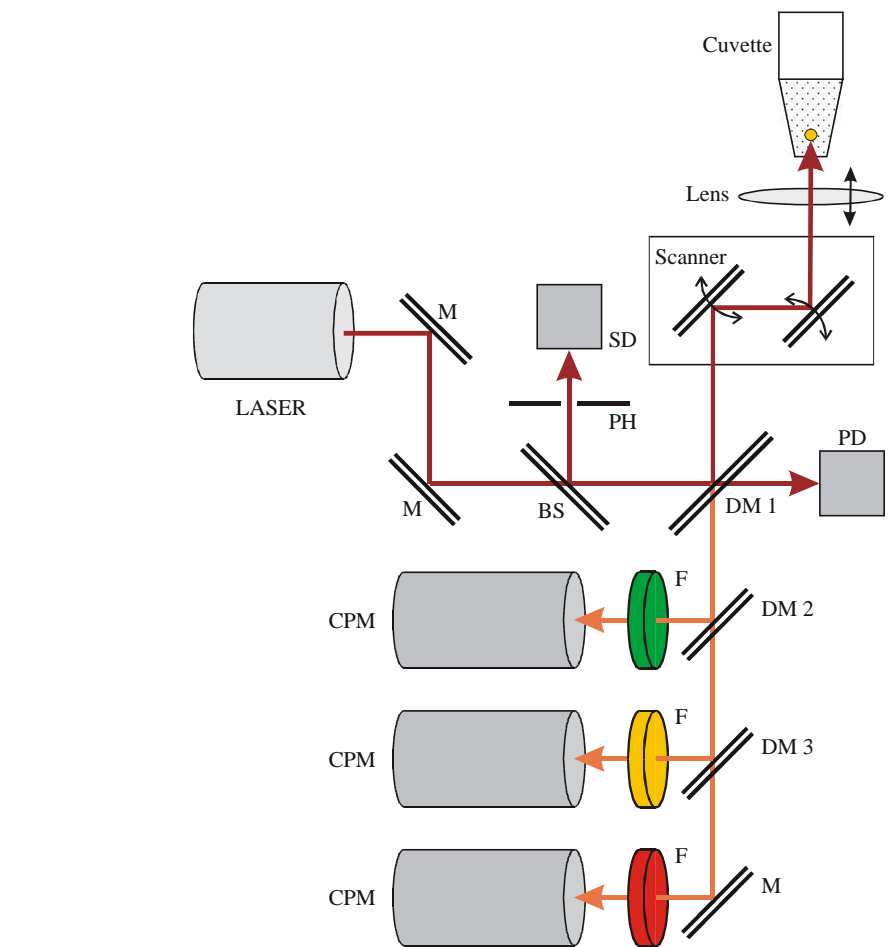

Fig 1. Optical schematic of the instrument

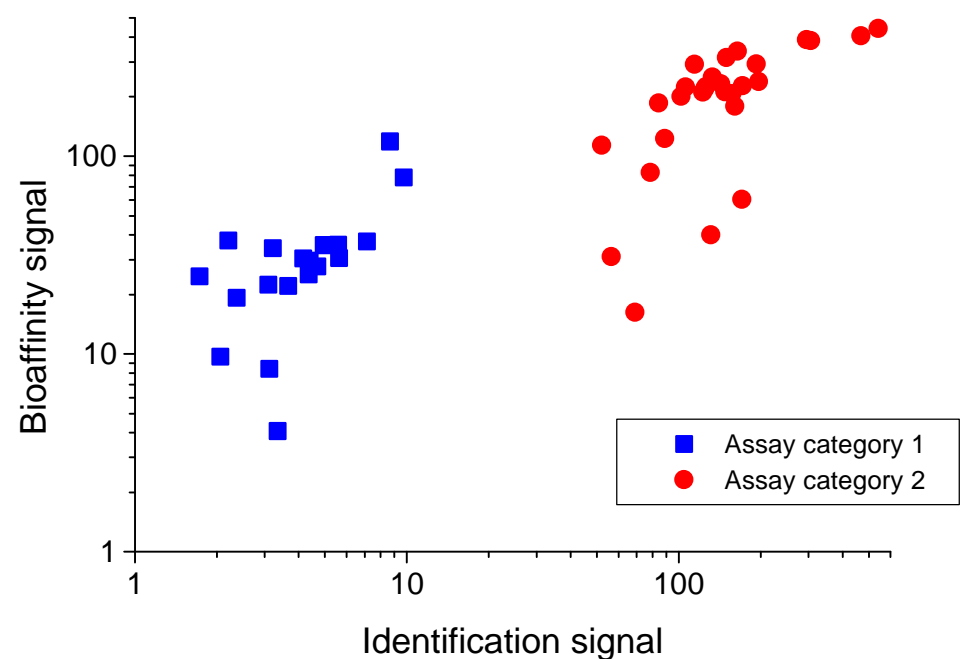

Fig 3. Dot plot of mixture of microspheres of two different immunoassays

Conclusion

The method based on two-photon fluorescence excitation makes possible fast single step, separation free multiparameter immunoassays, for example, for whole blood samples. The method allows a separation free assay in very small volumes, i.e. less than 1 μl , the method is very useful for high throughput screening assays.

References:

- Pekka Hänninen, Alekski Soini, Niko Meltola, Juhani Soini, Jori Soukka and Erkki Soini, *A new microvolume technique for bioaffinity assays using two-photon excitation*, 2000, **Nature Biotechnology**, 18, 548-550
- Juhani T. Soini, Jori M. Soukka, Alekski E. Soini, Niko J. Meltola Erkki Soini and Pekka E. Hänninen, *Ultra sensitive bioaffinity assay for micro volumes*, 2000, **Single Molecules**, 1, 3, 203-206